

MOTORE MINIBIKE - SCOOTERINO Air HP 6,2

SET ESTRATTORI E CHIAVI PER SMONTAGGIO MOTORE 143.695.000
 ESTRATTORE VOLANO M22X1,5 143.695.001
 CHIAVE SERRAGGIO PER PIGNONE 143.695.002
 ESTRATTORE PER APERTURA CARTER 143.695.003

Cod. 143.160.009 frizione completa
 △ Cod. 143.255.001 set molle (Ø filo: 1,6 - 2,3 - 2,3)
 ○ Cod. 143.705.008 - Cod. 143.705.014 Racing
 □ Cod. 143.705.009

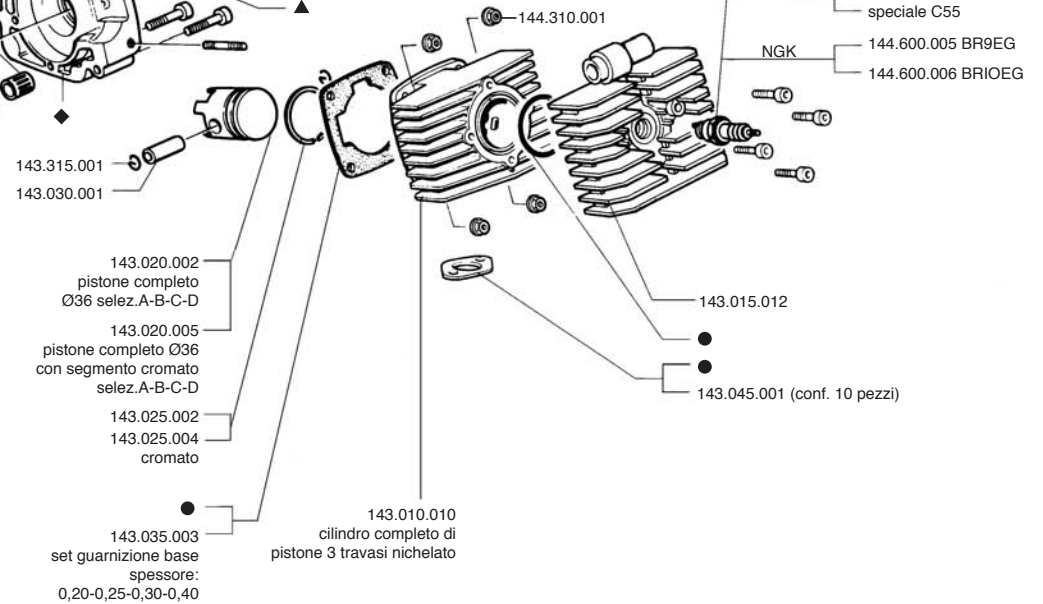
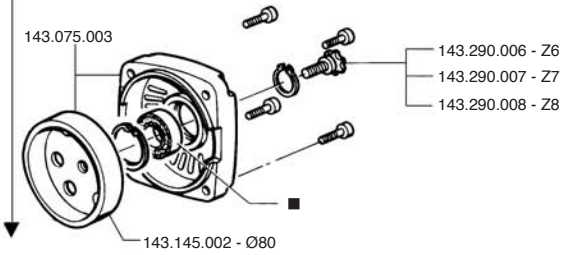
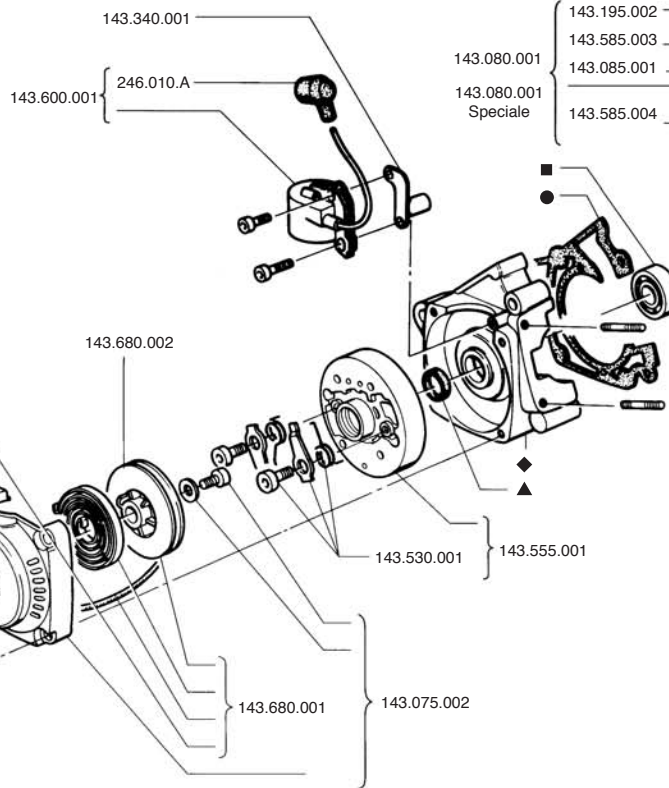
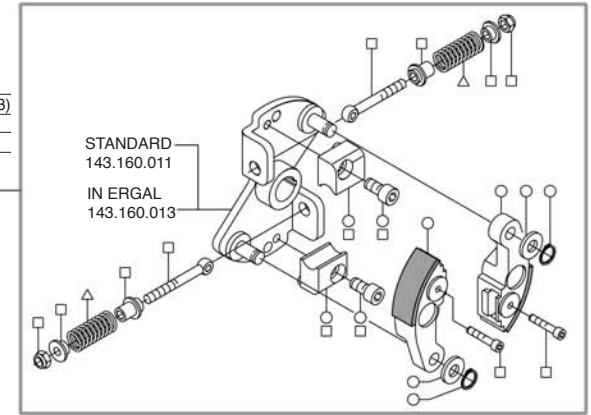
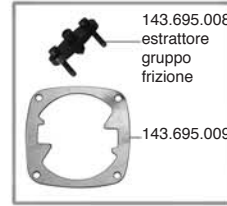
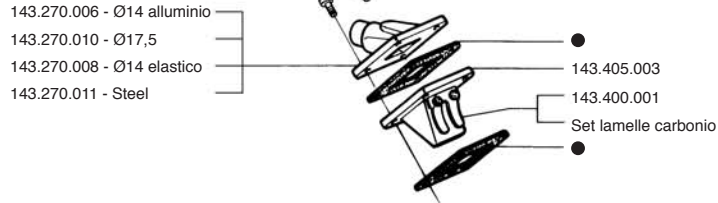

◆ CARTER MOTORE DESTRO+SINISTRO	143.070.002	SERIE VITI E DADI MOTORE	143.305.002
■ SERIE CUSCINETTI	143.190.001	IMPIANTO CARBURATORE Ø15	143.440.008
▲ SERIE PARAOLI BASAMENTO	143.065.001	IMPIANTO CARBURAT. PHVA Ø17,5	143.440.004
● SERIE GUARNIZIONI	143.034.001	SERIE ESTRATTORI MOTORE	143.695.000

PARTICOLARI